

**INDICATOR POST STYLE 2945
FIXED LENGTH ASSEMBLY
UL AND FM APPROVED**

KENNEDY VALVE

Available in Sizes F G H
See Page 6 for Dimensions

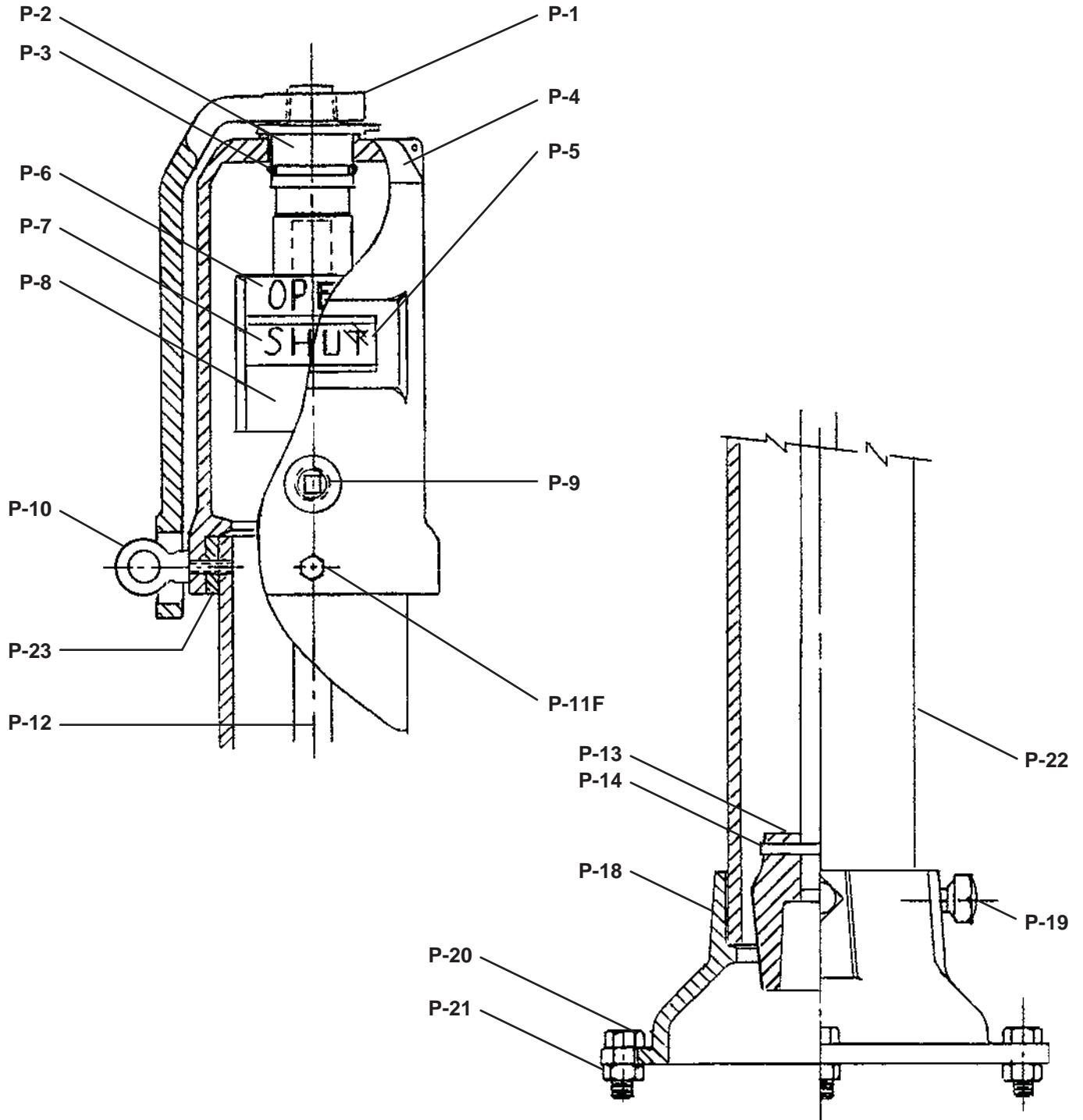

INDICATOR POST STYLE 2945 FIXED LENGTH UL/FM DIMENSIONS AND INSTRUCTIONS

KENNEDY VALVE

Available in Sizes F G H
See Page 6 for Dimensions

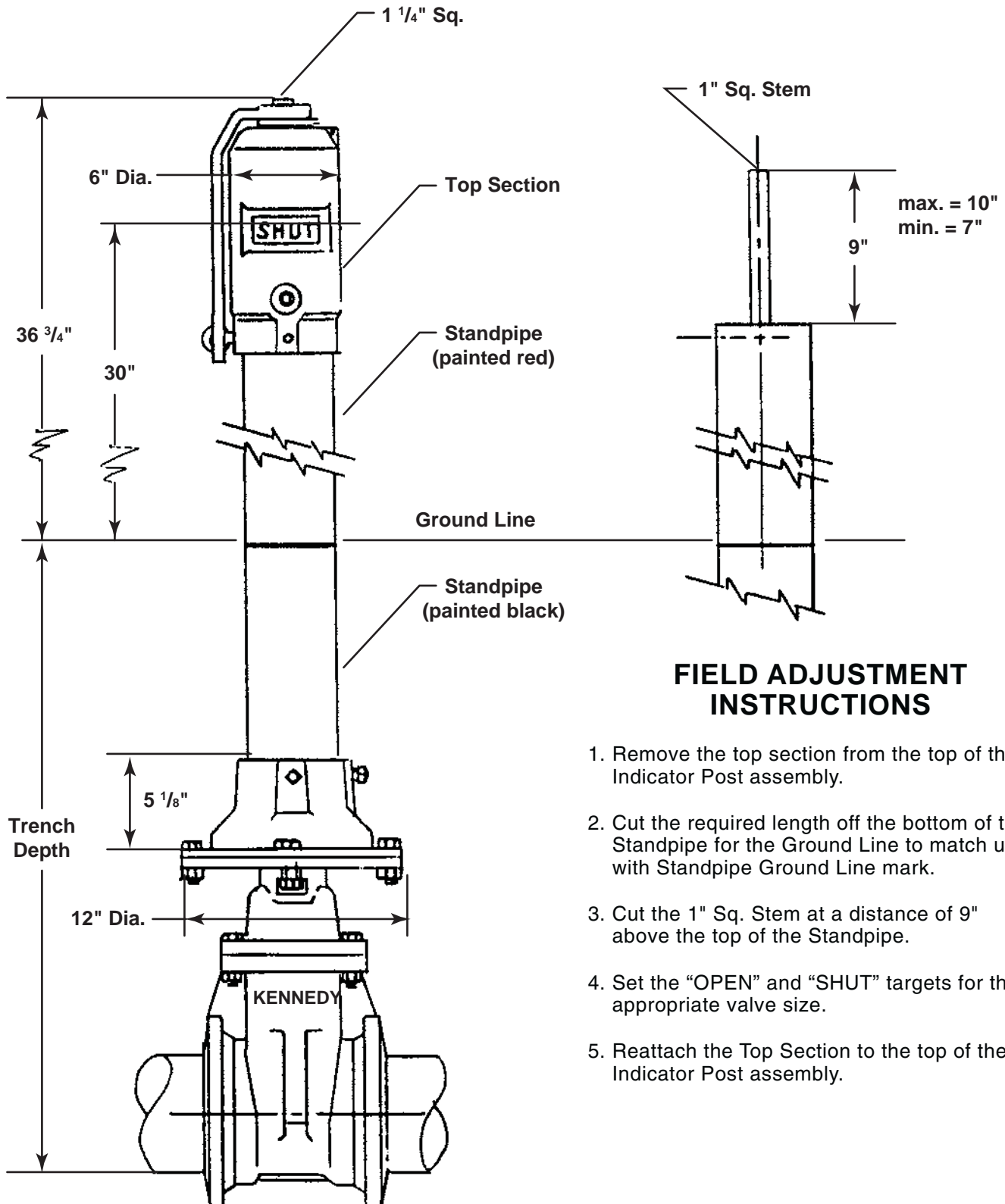

INDICATOR POST STYLE 2945 A (ADJUSTABLE) AND STYLE 2945 (FIXED) - PARTS LIST

KENNEDY VALVE

DET	QTY.	PART NO.	DESCRIPTION	MATERIAL
P-1	1	3361270	Locking Wrench	Cast Iron ASTM A-126 CI.B
P-2	1	3024872 (4-14")	Operating Nut	Bronze ASTM B584 Alloy 864
P-3	1	442639P	Retainer O-Ring #226	Buna N
P-4	1	3020913	Top Section	Cast Iron ASTM A-126 CI.B
P-5	2	441980P	Window Glass	Lexan - UV Stabilized
P-6	2	443370P	Open Target	Cast Aluminum
P-7	2	443371P	Shut Target	Cast Aluminum
P-8	1	—	Target Carrier Assem.	
	1	3005802 (4-14")	Target Carrier Nut	Bronze ASTM B584 Alloy 844
	2	443347P	Target Carrier Plate	1/16" Sheet Metal
	4	440736P	Clamp Target Retainer	16 Ga. 302 S.S.
	8	444171P	#10-24x1/2 " Pan Head	Stainless Steel
	4	442411P	#10-24 Hex Nut	Zinc Plated steel
P-9	1	443476P	1/2" NPT Pipe Plug	Mall. Iron
P-10	1	440254P	3/8" Eyebolt #23	Forged Steel
P-11A 1		444303P	3/8-16x1" Hex Capscrew (Adj. Post)	Zinc Plated Steel
P-11F 2		444306P	3/8-16x1 1/2" Hex Capscrew (Fixed Post)	Zinc Plated Steel
P-12	1	**	Stem 1" Sq.	AISI M1020 HRS
P-13	1	318035&	Crane Coupling	Cast Iron ASTM A-126 CI.B
P-14	1	442190P	Cotter Pin	Brass
P-15	2	444342P	3/4" Hex Hd. Screw	Zinc Plated Steel
P-16	1	3004774	Telescoping Barrel	Cast Iron ASTM A-126 CI.B
P-17	1	**	Lower Standpipe (Adjustable Post)	4" D.I. CI 52 ANSI A21.51
P-18	1	3180402 (3-12")	Base Flange	Cast Iron ASTM A-126 CI.B
P-19	3	444355P	5/8"x1" Hex Hd. Screw	Zinc Plated Steel
P-20	4	444357P	5/8"x2 1/4" Hex Capscrew	Zinc Plated steel
P-21	4	442484P	5/8" Hex Nut	Zinc Plated Steel
P-22	1	**	Standpipe Section (Fixed Post)	4" D.I. CI 52 ANSI A21.51
P-23	1	3004762	Spacer Sleeve (Fixed Post)	5" D.I. CI 52 ANSI A21.51

**Part numbers change based on post furnished.

AA
A
AA

**INDICATOR POST STYLE 2945A & 2945
TRENCH DEPTHS FOR GATE VALVES
UL & FM APPROVED**

KENNEDY VALVE

**TELESCOPING BARREL 2945A
TRENCH DEPTH LIMITS**

Valve Size	B Size		C Size		D Size		E Size	
	Min.	Max.	Min.	Max.	Min.	Max.	Min.	Max.
4"	31"	51"	49"	69"	67"	87"	88"	111"
6"	35"	55"	53"	73"	71"	91"	92"	115"
8"	42"	62"	60"	80"	78"	98"	99"	122"
10"	45"	65"	63"	83"	81"	101"	102"	125"
12"	49"	69"	67"	87"	85"	105"	106"	129"
14"/16"	58"	78"	76"	96"	94"	114"	115"	138"

**FIXED LENGTH POSTS 2945
MAXIMUM TRENCH DEPTH**

Valve Size	F Size	G Size	H Size
4"	45 1/2"	63 1/2"	87 1/2"
6"	49 1/2"	67 1/2"	91 1/2"
8"	54 1/2"	72 1/2"	96 1/2"
10"	59"	77"	101"
12"	64"	82"	106"
14"	69"	87"	111"

CHANGING THE TRENCH DEPTHS FOR GATE VALVES

A

INDICATOR POSTS 2945A & 2945 TRENCH DEPTHS FOR GATE VALVES UL & FM APPROVED