

OS&Y WITH HANDWHEEL

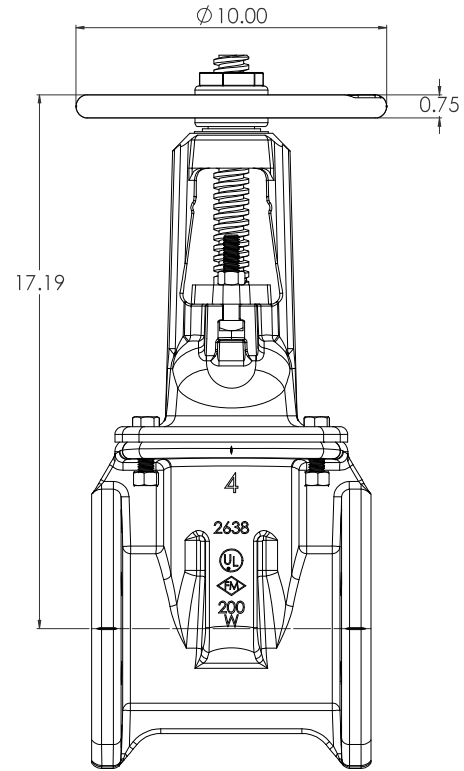

COMPANY: SOLO WORKS ADDRESS: 10000 W. 10th Ave., Suite 100, Golden, CO 80401 PHONE: (303) 440-1000 FAX: (303) 440-1001 WWW: www.soloworks.com		PROJECT: 04" C515 OS&Y RESILIENT WEDGE GATE VALVE LBS: 1:5 DATE: 10/01/2020		 2638 200 W	 3 6
DATE: 10/01/2020 DRAWN BY: CW CHECKED BY:	SCALE: 1:5 SHEET NO: 6 TOTAL SHEETS: 6	PROJECT NO:	DRAWING NO:	REVISIONS:	APPROVED BY:

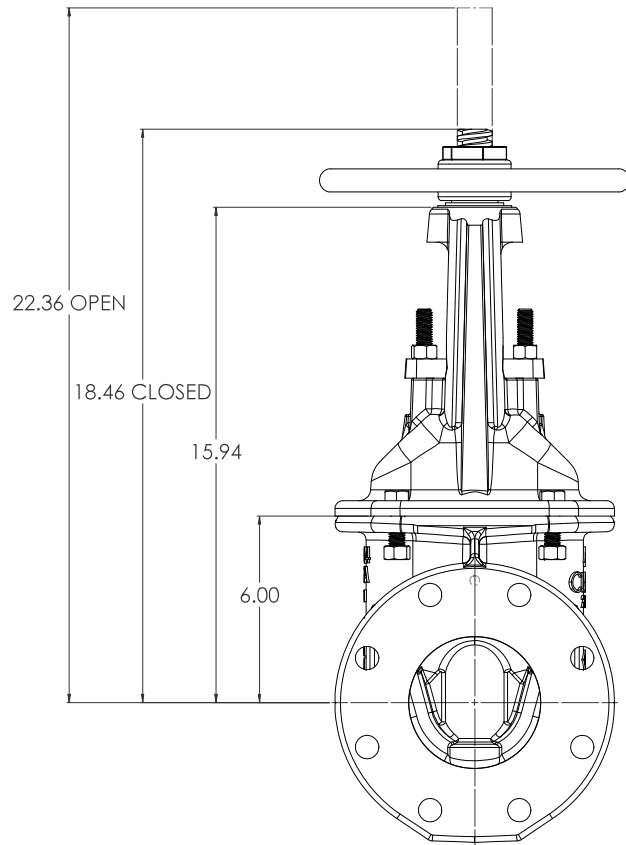
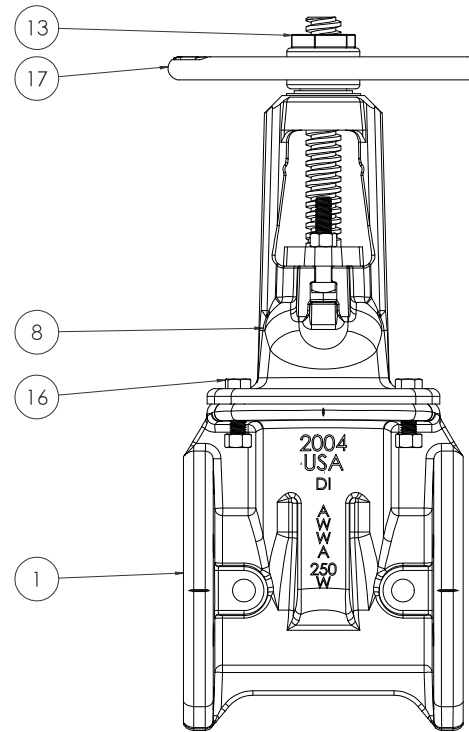
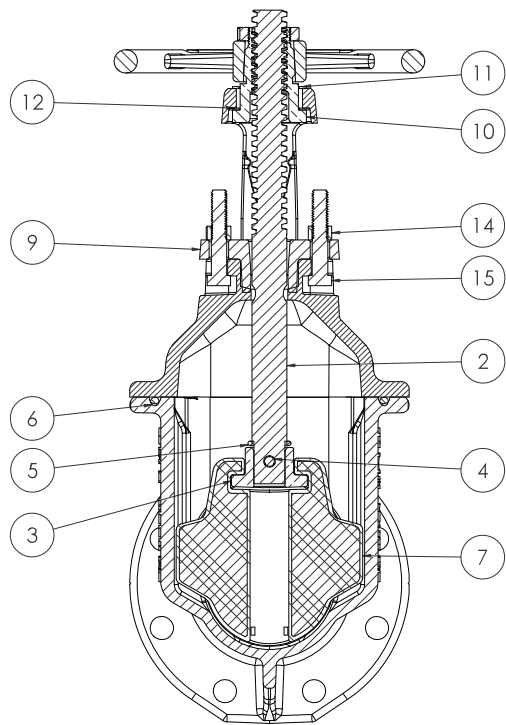

COMPANY: OS&Y VALVE CO. ADDRESS: 1000 W. 10th St., Tulsa, OK 74106 PHONE: (918) 436-2000 FAX: (918) 436-2001 WWW.OSANDY.COM		DRAWING NO.: 04-C515 TITLE: 04" C515 OS&Y RESILIENT WEDGE GATE VALVE		
DATE: 10/01/2008 BY: CW CHECKED: 10/01/2008 BY:	SCALE: 1:5 SHEET NO.: 6 TOTAL SHEETS: 6	WEIGHT: LBS. MATERIAL: 2004 USA DI	PART NO.: 2004 USA DI MANUFACTURED IN: USA	

<u>ITEM NO.</u>	<u>COMPONENT</u>	<u>QTY.</u>	<u>SIZE</u>	<u>STANDARD MATERIAL</u>	<u>MATERIAL OPTIONS</u>
1	BODY	1	-	DUCTILE IRON	-
2	STEM	1	-	C65500	304 SS, 316 SS
3	STEM NUT	1	-	C-87850	C87610 (LOW ZINC)
4	DRIVLOK PIN	1	5/16"X1 1/2	18-8 SS	316 SS
5	O-RING	1	#216	EPDM	BUNA-N
6	O-RING	1	#437	EPDM	BUNA-N
7	WEDGE	1	-	EPDM/DUCTILE IRON	-
8	COVER	1	-	DUCTILE IRON	-
9	GLAND	1	-	CAST IRON	-
10	TOP STEM NUT	1	-	C86700	-
11	LOWER THRUST WASHER	1	2 3/32"	C26000	-
12	THRUST WASHER	1	1 15/16"	NYLATRON	-
13	HOLD DOWN NUT	1	-	C87850	C87610
14	HEX NUT	6	1/2"-13	18-8 SS	316 SS
15	SQUARE HEAD CAP SCREW	2	1/2"-13 X 2 3/4"	18-8 SS	316 SS
16	HEX HEAD CAP SCREW	4	1/2"-13 X 1 3/4"	18-8 SS	316 SS
17	HANDWHEEL	1	10" DIA.	DUCTILE IRON	-

- VALVES CONFORM WITH THE FOLLOWING STANDARDS
 - AWWA C515
 - NSF 61
- LOW ZINC BRASS STEM AVAILABLE
- 100% DOMESTIC FASTENERS AND ORINGS OPTIONS AVAILABLE
- *OPEN LEFT* (COUNTERCLOCKWISE) AND *OPEN RIGHT* (CLOCKWISE) OPTIONS AVAILABLE
- TURNS TO OPEN FROM FULLY CLOSED: 15
- AWWA MAXIMUM ALLOWABLE CLOSING TORQUE 75 FT-LBS

<small>OS&Y VALVE COMPANY</small> <small>10000 W. 10TH AVENUE, SUITE 100, DENVER, CO 80231</small> <small>TEL: 303.440.1000 FAX: 303.440.1001</small> <small>WWW.OS&Y.COM</small>		<small>REVISED</small> <small>DATE</small> <small>BY</small> <small>CHKD</small> <small>APP'D</small> <small>DATE</small>	<small>REVISED</small> <small>DATE</small> <small>BY</small> <small>CHKD</small> <small>APP'D</small> <small>DATE</small>	<small>REVISED</small> <small>DATE</small> <small>BY</small> <small>CHKD</small> <small>APP'D</small> <small>DATE</small>	<small>REVISED</small> <small>DATE</small> <small>BY</small> <small>CHKD</small> <small>APP'D</small> <small>DATE</small>
<small>04" C515 OS&Y RESILIENT WEDGE GATE VALVE</small> <small>LBS.</small>		<small>1:5</small>		<small>10/01/2020</small>	
<small>5</small>		<small>6</small>		<small>D</small>	