

08" C509 FLG X FLG

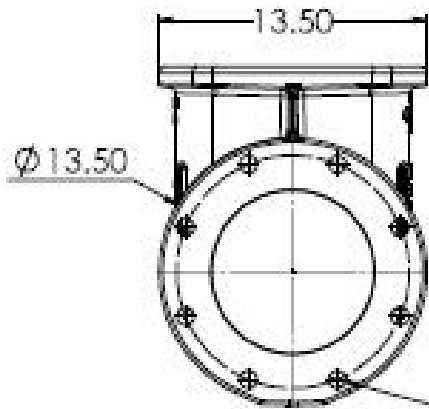

8 X $\varnothing 0.88$ ON
 $\varnothing 11.75$ B.C.
 FLG END:
 ANSI B16.1
 CLASS 125

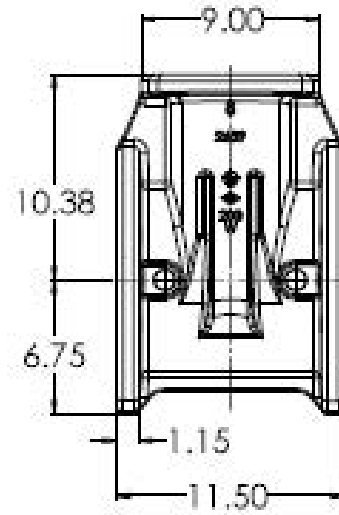

OTHER END CONNECTIONS ARE AVAILABLE UPON REQUEST.

08" C509 FLG X FLG <small>CONNECTION TO FLANGE, FLANGE TO FLANGE, AND FLANGE TO PIPE CONNECTIONS ARE AVAILABLE TO ORDER. CONTACT SALES FOR MORE INFORMATION.</small>		<small>REVISIONS</small> REVISION NO. 1 DATE 12/22/2020 BY CW	<small>DESIGNER</small> NAME DATE BY	<small>MANUFACTURER</small> NAME ADDRESS CITY STATE ZIP	<small>QUANTITY</small> 1	<small>UNIT OF MEASURE</small> LBS	<small>SCALE</small> 1:5	<small>DATE</small> 12/22/2020	<small>PROJECT</small> 2018 SP2	<small>WORKSHEET</small> 5	<small>OF</small> 5
--	--	--	---	--	------------------------------	---------------------------------------	-----------------------------	-----------------------------------	------------------------------------	-------------------------------	------------------------

OS&Y WITH HANDWHEEL

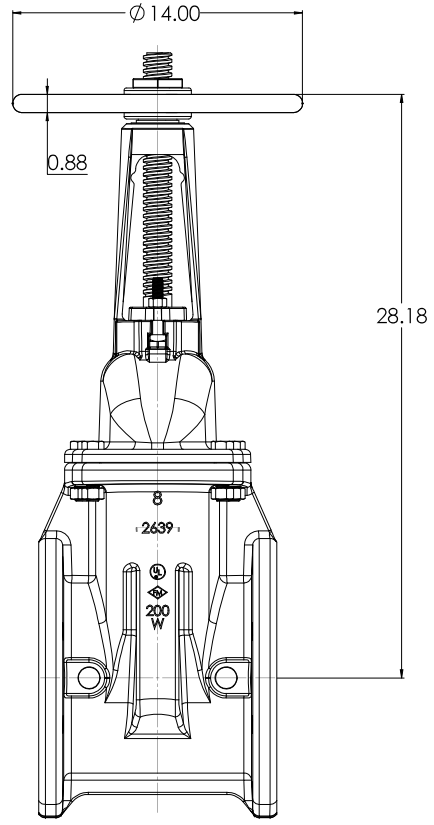
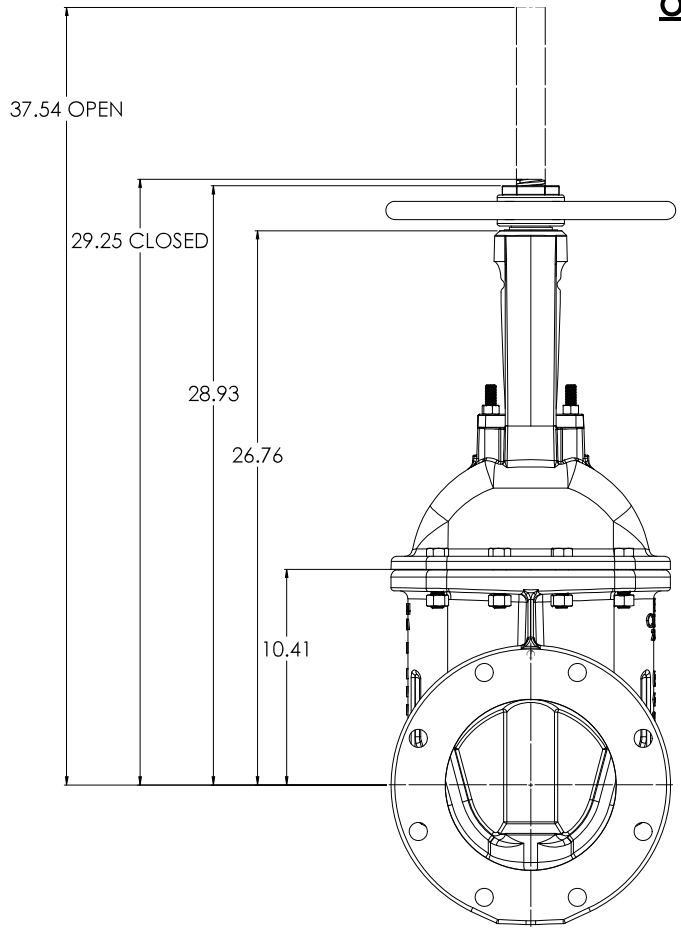

COMPANY: SOLO WORKS ADDRESS: 122720200 PHONE: 1-800-368-7777 FAX: 1-800-368-7777 E-MAIL: info@soloworks.com WEBSITE: www.soloworks.com		PROJECT: 08" C509 OS&Y RESILIENT WEDGE GATE VALVE DRAWING NO: LBS-GATE VALVE SCALE: 1:5 DATE: 12/2/2020		SHEET NO: 2 TOTAL SHEETS: 5 REVISION: D
--	--	--	--	--

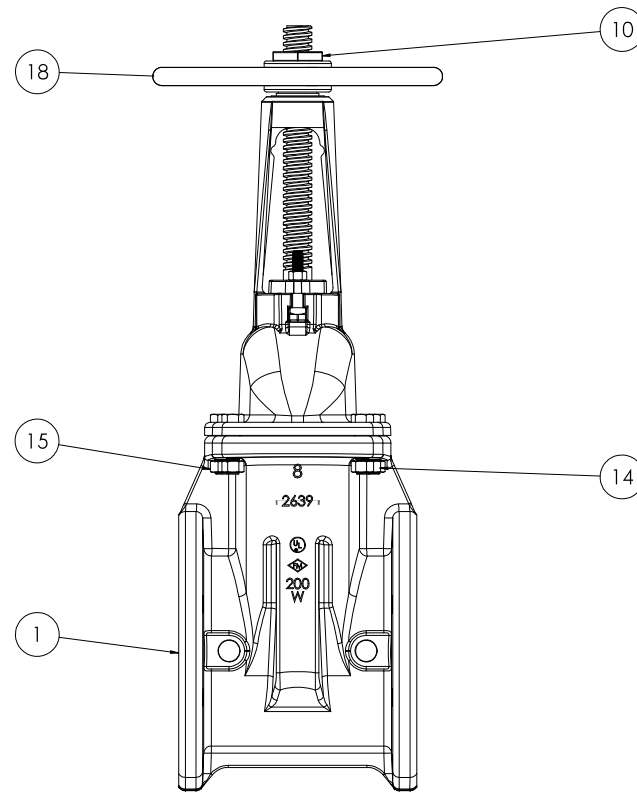
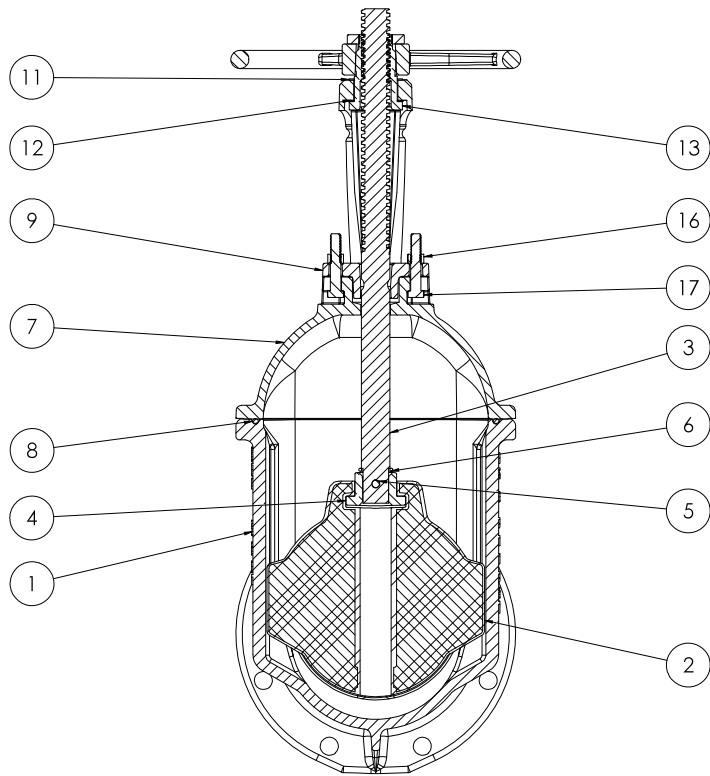

COMPANY SOLEWORKS 12292020		PROJECT 08" C509 CS&Y RESILIENT WEDGE GATE VALVE		SCALE 1:5		DATE 12/2/2020		REV 5		APP CW		CHK 12/2/2020		DRW 5		REV 5		APP CW		CHK 12/2/2020		DRW 5	
---	--	---	--	---------------------	--	--------------------------	--	-----------------	--	------------------	--	-------------------------	--	-----------------	--	-----------------	--	------------------	--	-------------------------	--	-----------------	--

<u>ITEM NO.</u>	<u>COMPONENT</u>	<u>QTY.</u>	<u>SIZE</u>	<u>STANDARD MATERIAL</u>	<u>MATERIAL OPTIONS</u>
1	BODY	1	-	CAST IRON	DUCTILE IRON
2	WEDGE	1	-	EPDM/DUCTILE IRON	-
3	STEM	1	-	C65500	304 SS, 316 SS
4	STEM NUT	1	-	C87610	C87850, C87845, C89833, C99500
5	DRIVLOK PIN	1	3/8" X 2"	303 SS	-
6	O-RING	1	#220	EPDM	BUNA-N
7	COVER	1	-	CAST IRON	DUCTILE IRON
8	O-RING	1	#447	EPDM	BUNA-N
9	GLAND	1	-	CAST IRON	-
10	HOLD DOWN NUT	1	-	C87850	C87610
11	THRUST WASHER	1	-	C26000	-
12	THRUST WASHER	1	2 5/32"	NYLATRON	-
13	TOP STEM NUT	1	-	C86700	-
14	HEX HEAD CAP SCREW	8	5/8"-11 X 2 1/2"	18-8 SS	316 SS
15	HEX NUT	8	5/8"-11	18-8 SS	316 SS
16	HEX NUT	2	1/2"-13	18-8 SS	316 SS
17	SQUARE HEAD CAP SCREW	2	1/2"-13 X 2 3/4"	18-8 SS	316 SS
18	HANDWHEEL	1	Ø 14"	DUCTILE IRON	-

- VALVES CONFORM WITH THE FOLLOWING STANDARDS
 - AWWA C509
 - NSF 61
- LOW ZINC BRASS STEM AND STEM NUT AVAILABLE
- 100% DOMESTIC FASTENERS AND ORINGS OPTIONS AVAILABLE
- *OPEN LEFT* (COUNTERCLOCKWISE) AND *OPEN RIGHT* (CLOCKWISE) OPTIONS AVAILABLE
- TURNS TO OPEN FROM FULLY CLOSED: 26
- AWWA MAXIMUM ALLOWABLE CLOSING TORQUE 150 FT-LBS

<small> COMPANY: WATERWORKS ADDRESS: 12345 INDUSTRIAL BLVD CITY: CHICAGO, IL 60601 PHONE: 773-555-1234 FAX: 773-555-5678 EMAIL: SALES@WATERWORKS.COM </small>		<small> PROJECT: 08" C509 CS&Y RESILIENT WEDGE GATE VALVE DRAWING NO: 100-100-100-100 DATE: 12/2/2020 SCALE: 1:5 SHEET NO: 4 OF 5 </small>		
<small> DESIGNED BY: JW CHECKED BY: JK DATE: 12/2/2020 </small>	<small> MATERIALS: 18-8 SS, 316 SS, DUCTILE IRON, EPDM, NYLATRON WEIGHT: 150 LBS </small>	<small> MANUFACTURED BY: WATERWORKS LOCATION: CHICAGO, IL </small>	<small> PROJECT NO: 100-100-100-100 SHEET NO: 4 OF 5 </small>	<small> DRAWN BY: JW DATE: 12/2/2020 </small>